

# DOUBLE ACTING SPRING HINGE TYPE 3044

## INSTALLATION INSTRUCTIONS

- 1) REMOVE SPRING TENSION FROM EACH BARREL BY INSERTING TENSION ROD INTO THE TENSION ADJUSTMENT HOLE, ROTATE IN DIRECTION OF THE ARROW, AS SHOWN IN FIGURE 2 OR FIGURE 3, AND REMOVE TENSION PIN.
- 2) LOCATE HINGES AS SHOWN IN FIGURE 1.  
\* 3024 - BOX CLAMP MAY BE MORTISED OR SURFACE APPLIED TO DOOR EDGE.
- 3) ALIGN CENTERLINE OF DOOR WITH CENTERLINE OF FRAME AND SECURE THE FRAME LEAF.

FOR BEST ALIGNMENT OF DOUBLE DOORS, MOUNT HINGES ON ONE DOOR WITH TENSION ADJUSTMENT UP, AND DOWN ON THE OPPOSITE DOOR AS SHOWN IN FIGURE 1. SHIMS MAY BE NECESSARY UNDER THE EDGES OF THE FRAME FLANGES FOR DOOR ALIGNMENT.

## SPRING TENSIONING INSTRUCTIONS

DO NOT EXCEED FIVE (5) HOLES TENSION

- 1) PLACE DOOR IN CLOSED POSITION. WEDGE DOOR UP FROM FLOOR UNTIL IT IS PLUMB.
- 2) INSERT TENSION ROD INTO THE TENSION ADJUSTMENT HOLE, ROTATE IN DIRECTION OF ARROW, AS SHOWN IN FIGURE 2 OR FIGURE 3. (ONLY ONE HOLE OF TENSION IS RECOMMEND FOR BOTTOM HINGES)
- 3) INSERT TENSION PIN, AND REMOVE THE TENSION ROD.
- 4) INCREASE TENSION ON THE TOP HINGES IF DOOR SAGS OR RETURN ACTION IS TOO SLOW.

-----NOTE-----

LUBRICATION MAY BE APPLIED TO HINGES, IF NEEDED.

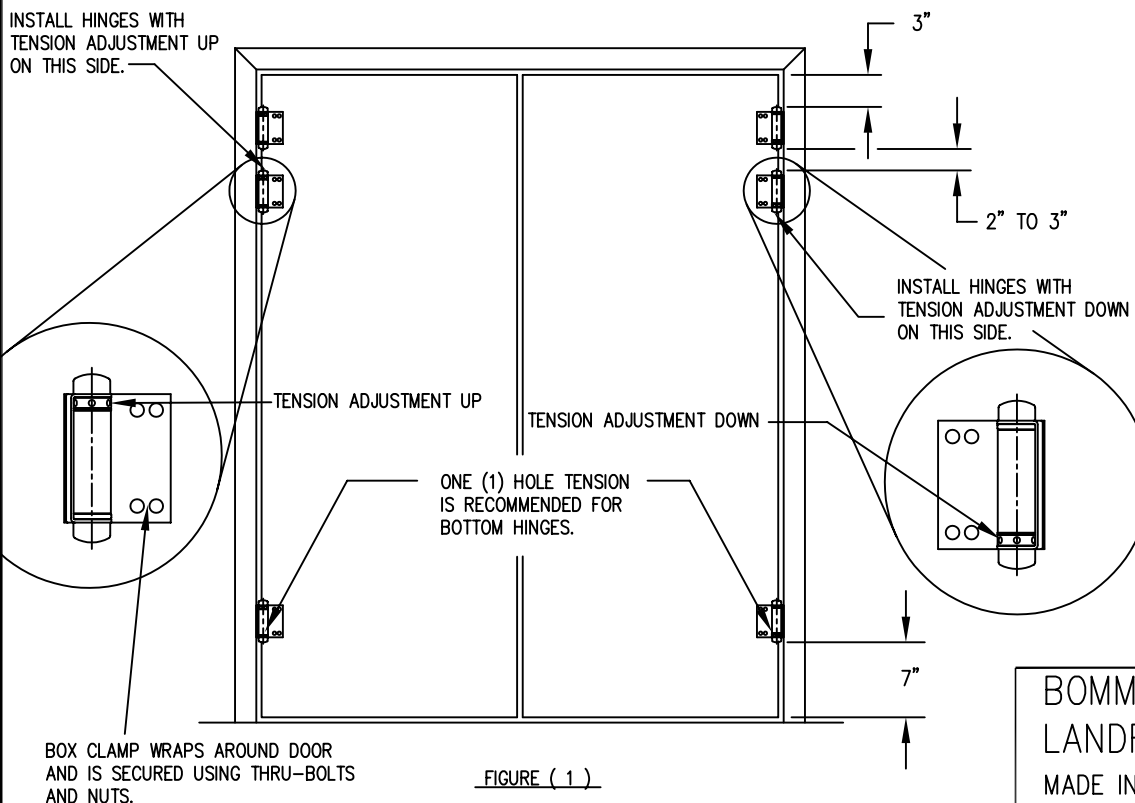
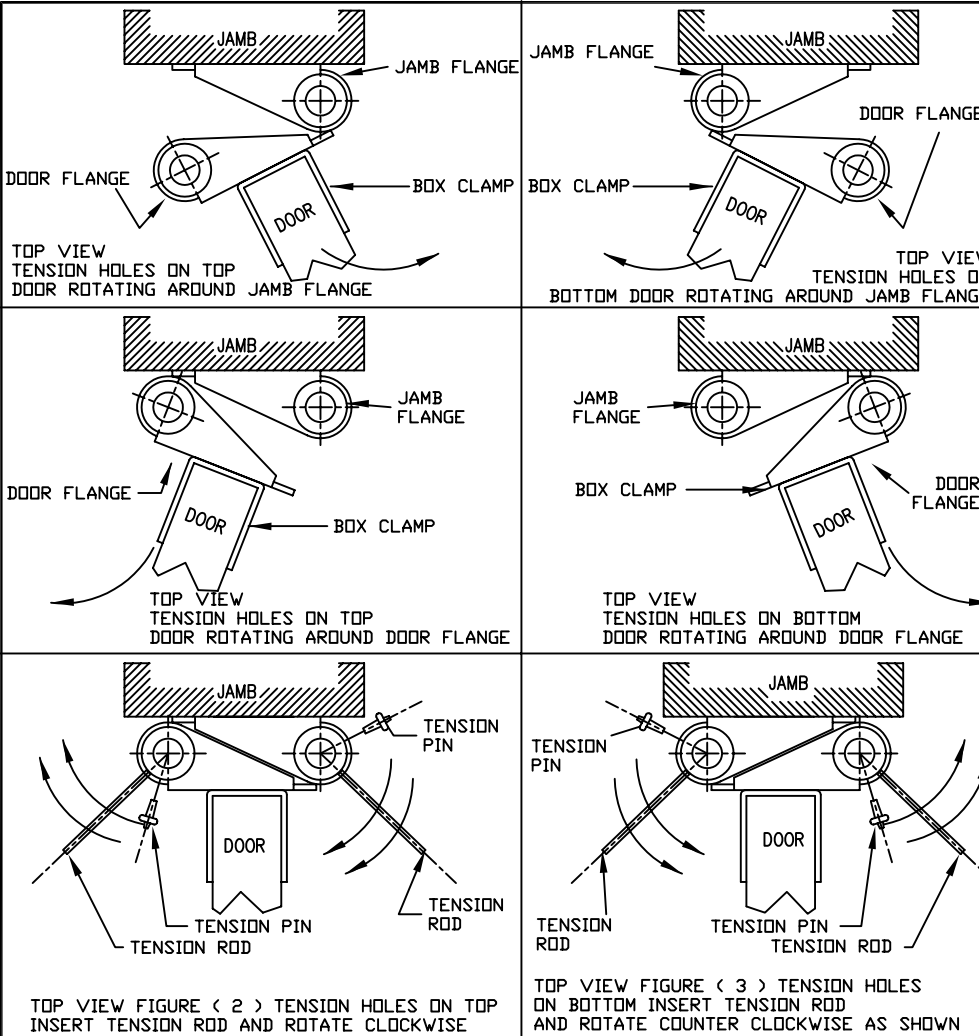

FIGURE ( 1 )

BOMMER INDUSTRIES, INC.  
LANDRUM, SC 29356  
MADE IN THE USA  
DOUBLE ACTING SPRING HINGE  
INSTALLATION INSTRUCTIONS 3044

DRAWN BY : STEWART JACKSON

DRAWING NUMBER

APPROVED BY :

3044-A

PLOT DATE : 23 JUN 2004

PURCHASE NO. 865583

THIS IS A CAD DRAWING...  
DO NOT REVISE MANUALLY.