

Bommer Industries Inc.  
 19810 Highway 176  
 P.O. Box 187  
 Landrum SC 29356

# TEMPLATE HINGES

FULL MORTISE – STANDARD WEIGHT

SIZES 3.5 x 3, 3.5 x 3.5, 3.5 x 5, 3.5 x 6 INCHES

DRAWING NOT TO SCALE

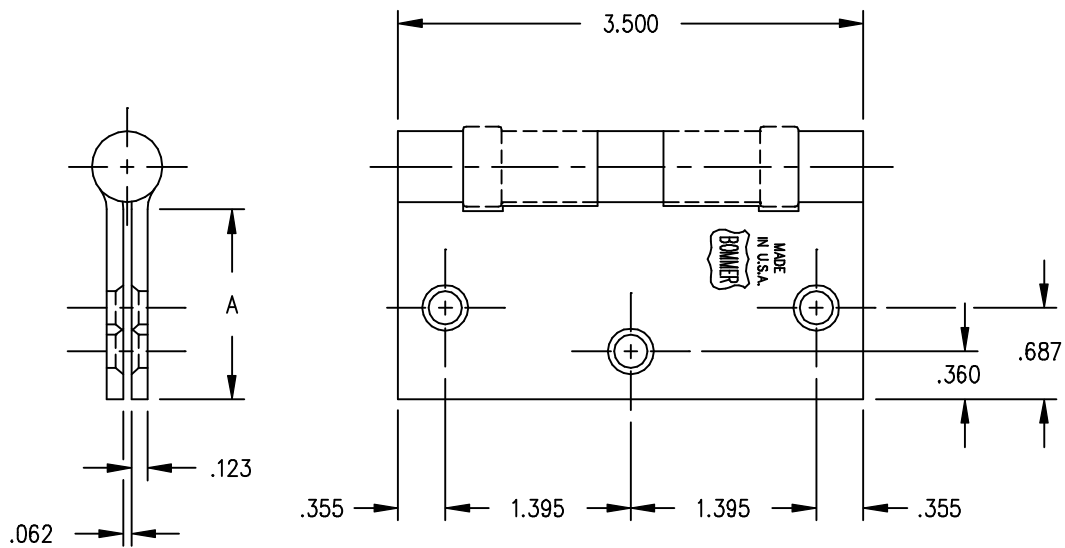

CATALOG NUMBER			(A) HINGE EDGE TO SWAGE LINE			
STEEL HINGES	BRASS OR BRONZE HINGES	STAINLESS STEEL HINGES	3.5 x 3 (353)	3.5 x 3.5 (350)	3.5 x 5 (355)	3.5 x 6 (356)
5000	5001	5002	1.187	1.437		
5010	5011	5012			2.187	2.687
8000	8001	8002		1.562		
BB5000	BB5001	BB5002	1.187	1.437		
BB5010	BB5011	BB5012			2.187	2.687
LB8000	LB8001	LB8002		1.562		

MACHINE SCREW SIZE – 1/2 X 10-24 F.H.  
 WOOD SCREW SIZE – 1 X NO.10 F.H.

TEMPLATE NO. 5000-350-T